

City of Bandon

CITY COUNCIL AGENDA DOCUMENTATION

DATE: 6/4/12

SUBJECT:
ORDINANCE 1594 - OUTDOOR LIGHTING REGULATIONS

ITEM NO:
5.B.2

BACKGROUND:

Preparation of the proposed Outdoor Lighting Regulations was initiated in 2010 by Nancy Noble Post who served as a volunteer intern in the Planning Department. She worked with the Committee for Citizen Involvement (CCI), Dave Ledig of USF&W, Sheryl Bremmer, the Planning Commission, and several members of the community to promote the important concept of keeping the night sky free from intrusive light. In September, 2011, the CCI scheduled a Community Forum at the Barn/Community Center. The intent of the Forum was to engage the public in an informative discussion regarding the protection of wildlife and preservation of the night sky.

On March 22nd, the Planning Commission opened a public hearing on proposed Outdoor Lighting Regulations. Based on public input, the Commission continued that hearing to the April 26th meeting, and appointed a subcommittee (City Manager Matt Winkel, Planning Commissioner Sheryl Bremmer, and Nancy Noble Post) to amend the proposed regulations and bring back for Commission review a draft of revised regulations. At that meeting, since there had not been sufficient time for the subcommittee to complete the final review and final document preparation, the Planning Commission continued the matter to the May 24th meeting. At that time the Commission again reviewed and revised the proposed regulations, and unanimously recommended that they be approved by the City Council.

Proposed Ordinance 1594, adopting the Outdoor Lighting Regulations, is attached.

FISCAL IMPACT:

Undetermined.

RECOMMENDATION:

MOTION 1: Pass Ordinance No. 1594 to a second reading.

MOTION 2: (If a full Council is present and the motion to pass to a second reading was approved unanimously): **MOTION: Adopt Ordinance No. 1594.**

SUBMITTED BY:



MATT WINKEL, CITY MANAGER

ORDINANCE NO. 1594

AN ORDINANCE OF THE MAYOR AND CITY COUNCIL OF THE CITY OF BANDON AMENDING THE BANDON MUNICIPAL CODE, TITLE 17 - ZONING, ADDING CHAPTER 17.98- OUTDOOR LIGHTING REGULATIONS.

WHEREAS, to protect and promote the public health, safety, and welfare, the quality of life, the ability to view the night sky, and to protect the natural environment from the damaging effects of night lighting, the Planning Commission has prepared a set of proposed Outdoor Lighting regulations; and

WHEREAS, after providing the required public notice and holding the required public hearing, the Planning Commission has recommended that amendments be made to the Bandon Municipal Code to add Chapter 17.98 - Outdoor Lighting; and

WHEREAS, the Mayor and City Council have determined that amending the Bandon Municipal Code to add Chapter 17.98 - Outdoor Lighting is the best interest of the City of Bandon;

NOW, THEREFORE, BE IT ORDAINED by the Mayor and City Council that the City of Bandon that Bandon Municipal Code, Title 17 - ZONING is amended to add Chapter 17.98 - Outdoor Lighting, which is attached hereto and incorporated herein by reference.

PASSED TO A SECOND READING by the City Council of the City of Bandon this 4th day of June, 2012, on a roll call vote, _____ : _____ .

ADOPTED by the City Council of the City of Bandon, this 4th day of June, 2012, on a roll call vote, _____ : _____ .

Mary Schamehorn, Mayor

Attest:

Matt Winkel, City Manager/Recorder

Bandon Municipal Code

Chapter 17.98

OUTDOOR LIGHTING

Sections

17.98.010 Purpose

17.98.020 Scope

17.98.030 General Provisions

17.98.040 Lighting Adjacent to Wildlife Areas

17.98.050 Exceptions to the Full Cut-off Requirement

17.98.060 Prohibitions

17.98.070 Enforcement

17.98.080 Definitions

17.98.010 Purpose

The general purpose of this Ordinance is to protect and promote the public health, safety and welfare, the quality of life, the ability to view the night sky, and to protect the natural environment from the damaging effects of night lighting, by establishing regulations and a process of review for exterior lighting. This Ordinance establishes standards for exterior lighting in order to accomplish the following:

- A. Permit reasonable uses of outdoor lighting for nighttime safety, utility, security, and enjoyment while preserving the ambiance of the night;
- B. Curtail and reverse any degradation of the nighttime visual environment and the night sky;
- C. Minimize glare and obtrusive light by limiting outdoor lighting that is misdirected, excessive, or unnecessary;
- D. Protect the wilderness and wildlife habitats adjacent to and within the Bandon City limits from damaging effects of night lighting. The Oregon Islands and the Bandon Marsh National Wildlife Refuge are important fish and wildlife habitats for a wide variety of resident and migratory wildlife. In addition, the rocks, reefs, islands, and beaches are important breeding, pupping, and resting grounds for a variety of marine mammals;
- E. Preserve and enhance the natural nighttime visual environment of Bandon, thus adding to the quality of life and economic well-being of the City as a destination resort community economically dependent upon tourists and part-time residents;
- F. Provide safe roadways for motorists, cyclists, and pedestrians;
- G. To ensure that sufficient lighting can be provided where needed to promote safety and security;
- H. To allow for flexibility in the style of lighting fixtures;

- I. To provide lighting guidelines to assist property owners and occupants in bringing nonconforming lighting into conformance with this Ordinance.

17.98.020 Scope

All exterior lighting installed after the effective date of this Ordinance in any and all zoning districts in the City of Bandon shall be in conformance with the requirements established by this Ordinance and any other applicable ordinances. This includes, but is not limited to, new lighting, replacement lighting, or any other lighting whether attached to structures, poles, the earth, or any other location, including lighting installed by any third party.

17.98.030 General Provisions

Pursuant to Section 17.98.020, the Planning Administrator and/or Planning Department shall have the authority to require lighting to meet the requirements of this Ordinance.

All exterior lighting shall be full cut-off fixtures with the following exception: Sensor activated lighting does not have to be full cut-off provided it is located in such a manner as to prevent direct glare and lighting into properties of others or into a public right-of-way, and provided the light is set only to go on when activated and to go off after five (5) minutes of activation, and the light shall not be triggered by activity off the property.

17.98.040 Lighting Adjacent to Wildlife Areas

The following outdoor lighting standards have been developed to protect the wilderness and wildlife habitat from the damaging effects of artificial light:

- A. Outdoor light fixtures shall be designed and positioned so as to avoid casting light on the beach, the offshore rocks, reefs, estuary, islands, estuary lands, the ocean, the Coquille River, the Oregon Islands, and the Bandon Marsh National Wildlife Refuge;
- B. Any lights that directly illuminate the beach or off-shore rocks or estuary habitats are prohibited.

17.98.050 Exceptions to the Full Cut-off Requirement

- A. All outdoor light fixtures lawfully installed prior to and operable on the effective date of this ordinance;
- B. Lighting of U.S. flags. Flags taken down at sunset avoid the need for lighting;
- C. When signs are being reviewed, signs will be designed to minimize light trespass skyward or onto adjacent properties and shall also comply with provisions in Section 17.90 of the Bandon Municipal Code;

- D. Replacement of bulbs and globes;
- E. Temporary lighting for theatrical, television, and performance areas (with temporary structure permit);
- F. Underwater lighting in swimming pools and underwater lighting of other water features;
- G. Temporary lighting and seasonal and/or holiday lighting provided that individual lamps are less than 10 watts and 70 lumens; less than 60 days use in any one calendar year;
- H. Vehicular lights and boat and watercraft lights while vehicle and boat and watercraft are being operated by a driver/operator;
- I. All temporary emergency lighting needed by the Fire and Police Departments, other emergency services, including but not limited to ambulances; and public utilities to perform their duties to maintain the public health, safety, and welfare;
- J. Temporary lighting for construction sites (with proper permit);
- K. Exit signs and other illumination required by building codes;
- L. Lighting for stairs and ramps, as required by the building code;
- M. Football, baseball, and softball field lighting; only with permit from the City recognizing that steps have been taken to minimize glare and light trespass and are turned off within one (1) hour after event is over;
- N. Landscape lighting powered at less than 15 volts and limited to luminaries having a rated initial luminaire lumen output of 525 lumens or less with no bulb higher than 24" above grade;
- O. Special event lighting only with permit from the City recognizing that steps have been taken to minimize glare and light trespass and are turned off within one hour after event is over;
- P. Porch lights or lights installed adjacent to entry doors (maximum 2 lights for front door and 1 light for each other door) with each light limited to a maximum of a 40 watt incandescent bulb or a 9-13 watt CFL EnergyStar Qualified bulb, or 450 lumens. The top of the bulb and fixture must be covered such that no light is directed upward. Aforementioned lights must be mounted on the building. (See figures 1 & 2.)

17.98.060 Prohibitions

The following lighting systems are prohibited from being installed or used except as specifically allowed by special use permit:

- A. Aerial lasers and searchlights;
- B. Temporary or permanent lighting that is installed inside of a building but intended to illuminate outside.

17.98.070 Enforcement

If, after investigation, the Planning Administrator and/or Planning Department finds that any provision of this Ordinance is being violated, the Administrator

and/or Planning Department shall give notice of such violation to the owner and/or to the occupant of such premises demanding that the violation be abated within thirty (30) days of the date of delivery or mailing of the notice. The Planning Department Staff shall be available to assist in working with the violator to correct said violation. If the violation is not abated within the thirty (30) day period, the Administrator and/or Planning Department may institute actions and proceedings, either legal or equitable, to enjoin, restrain, or abate any violations of this Ordinance and to collect the penalties for such violations.

17.98.080 Definitions

Unless specifically defined below, words or phrases used in this Ordinance shall be interpreted so as to give them the meaning they have in common usage and to give this Section its most reasonable application;

Bulb: The source of electric light; to be distinguished from the whole assembly (See Luminaire).

Existing Lighting: Any and all lighting installed prior to the effective date of this Ordinance.

Exterior Lighting: Temporary or permanent lighting that is installed, located, or used in such a manner to cause light rays to shine outside. Fixtures that are installed indoors that are intended to light something outside are considered exterior lighting for the intent of this Ordinance.

Fixture: The assembly that holds the lamp in a lighting system. It includes the elements designed to give light output control, such as a reflector (mirror) or refractor (lens), the ballast, housing, and the attachment parts.

Flood Light: Light designed to "flood" a well-defined area with light.

Full Cut-Off Fixtures: Fixtures, as installed, that are designed or shielded in such a manner that all light rays emitted by the fixture, either directly from the lamps or indirectly from the fixture, are projected below a horizontal plane running through the lowest point on the fixture where light is emitted. (See Figures 5, 6, 7). "Full cut-off fixtures" includes recessed lighting. (See Recessed below.)

Glare: Intense light that results in discomfort and/or a reduction of visual performance and visibility.

Holiday Lighting: Festoon type lights, limited to small individual bulbs on a string where the output per bulb is no greater than 15 lumens; also includes rope lighting. Internally lit decorative objects shall be limited to the equivalent of a 40 watt incandescent bulb.

Lamp: The source of electric light; the bulb and its housing; to be distinguished from the whole assembly (See Luminaire).

Light: The form of radiant energy acting on the retina of the eye to make sight possible; brightness; illumination; a lamp, as defined above.

Light Trespass: Light falling where it is not wanted or needed, generally caused by a light on a property that shines onto the property of others.

Lighting: Any or all parts of a luminaire that function to produce light.

Luminaire: The complete lighting unit, including the lamp, the fixture, and other parts.

Planning Administrator and/or Planning Department: The City of Bandon Planning Administrator, or a member of the City of Bandon Planning Department Staff, City Planner.

Recessed: When a light is built into a structure or portion of a structure such that the light is fully cut-off and no part of the light extends or protrudes beyond the underside of a structure or portion of a structure.

Temporary Lighting: Lighting that is intended to be used for a special event for seven (7) days or less. Also, lighting installed and operated for periods not to exceed sixty (60) days, completely removed and not operated again for at least thirty (30) days.

Uplighting: Lighting that is directed in such a manner as to shine light rays above the horizontal plane.

Drawings:

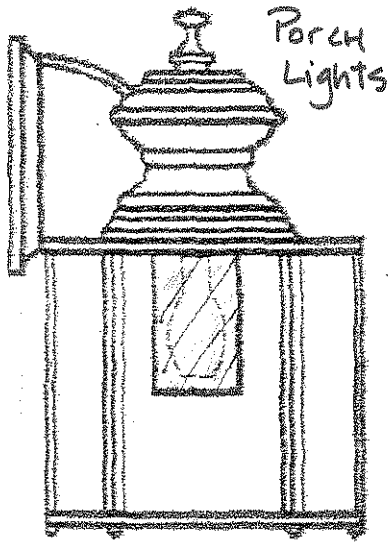

Porch Lights

Figure 1

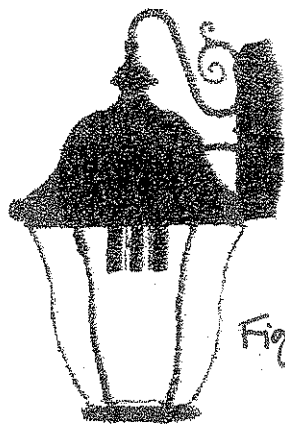
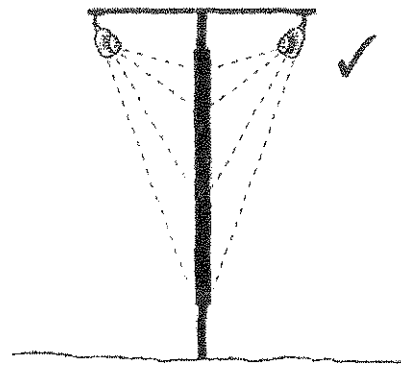
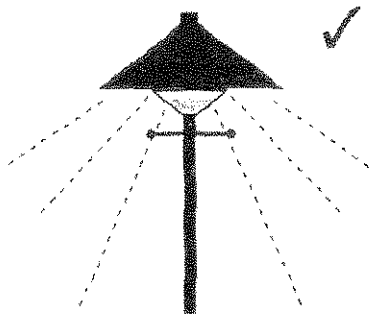

Figure 2



Top-mounted
Billboard Floodlights
(carefully focused onto billboard)

Figure 3



Post-style Lamp

Figure 4

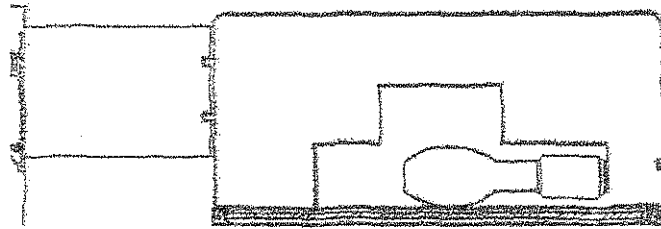

Figure 5A

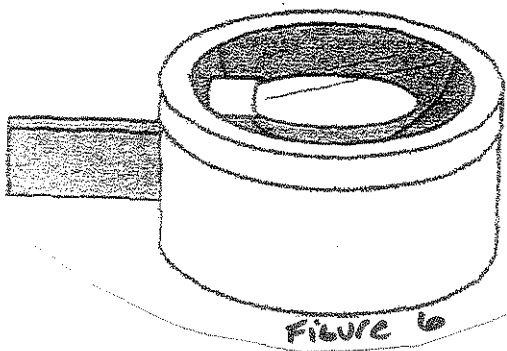
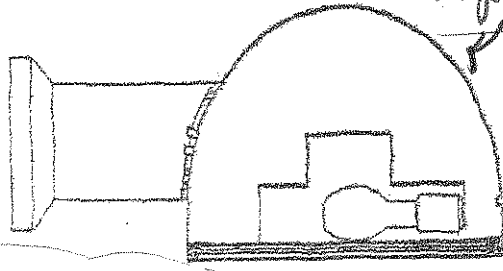

Figure 6

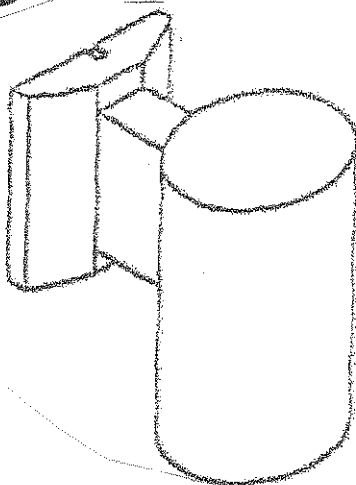

Figure 8

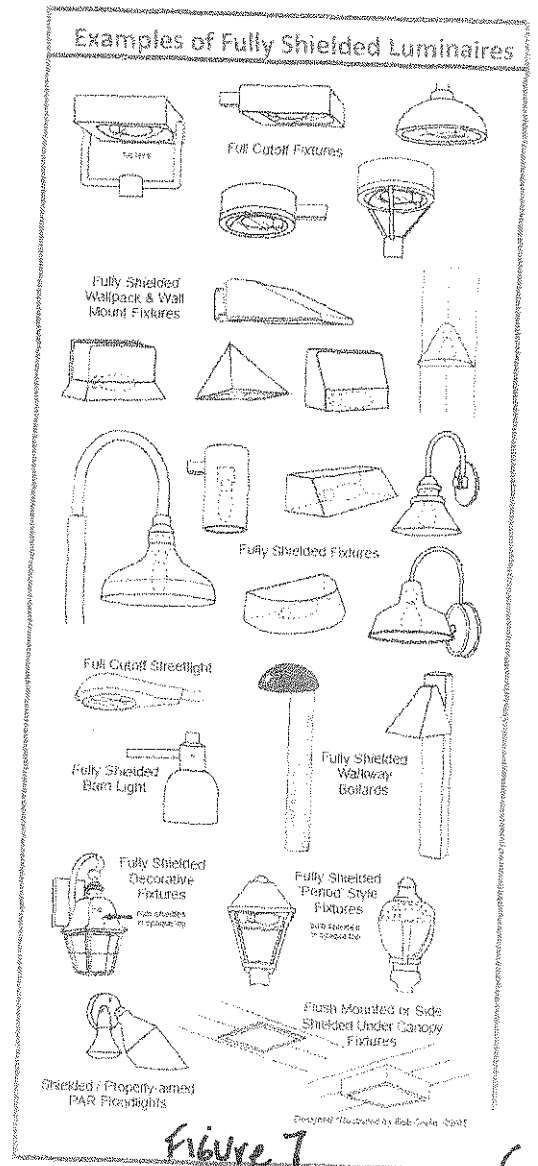

Figure 7